



— MODEL **124-01**
624-01

Float Valve

Description

The Cla-Val 124-01/624-01 is an automatic valve designed to open wide when liquid level reaches a predetermined low point and to shut drip tight when a predetermined high point is reached. It is a hydraulically operated, pilot controlled valve. The Pilot Valve is actuated by a float ball to limit the high and low liquid levels in the tank or reservoir by closing or opening the main valve. High and low liquid levels are adjustable. The float control can be remotely located only if the flowing line pressure at the valve inlet (in psi) is equal to or greater than the elevation (in feet) from the main valve to the float pilot control.

Installation

1. Allow sufficient room around the valve assembly for adjustments and maintenance.

NOTE: BEFORE VALVE IS INSTALLED, THE PIPELINE SHOULD BE FLUSHED OF ALL CHIPS, SCALE AND FOREIGN MATTER.

2. It is recommended that a gate or line block valve be installed upstream of the 124-01/624-01 Float Valve to facilitate isolating the valve for maintenance. If the discharge from the Float Valve is to atmosphere, an outlet shutoff valve may not be required.

3. Place the 124-01/624-01 Float Valve in the line with flow through the valve in the direction of flow arrows or by the inlet nameplate. Check all fittings and hardware for proper makeup or apparent damage. Be sure main valve cover bolts or cap screws are tight.

4. Cla-Val Valves operate with maximum efficiency when mounted in horizontal piping with the cover UP; however, other positions are acceptable. Installation with the cover up is advisable to make internal parts readily accessible for periodic inspection.

5. When the valve is installed over water in the tank or reservoir mount the valve to position the float rod and ball assembly (CF1-C1 item 3) **vertically down** from the valve.

6. If the surface of the water in the tank is subject to waves by wind or by valve discharge, **a stilling well must be installed around the float ball assembly.** 8" I.D. PVC pipe is suggested.

7. **INITIAL ADJUSTMENT.** See CF1-C1 on reverse side for proper assembly of the float rod, ball and stop collars and threading into the Link Assembly. Temporarily remove float. Adjust counterweight on the rod to balance the weight of the link assembly and float rod assembly, less the float. Replace float.

8. Move float rod to the "up" position. Adjust the upper stop collar on the float rod assembly approximately three inches above the high water level desired in the tank. Move float rod to "down" position. Adjust the lower stop collar on the float rod assembly approximately three inches below the desired low water level. Tighten stop collar screws on the CF1-C1.

Operation and Start-up

1. Prior to pressuring the valve assembly make sure the necessary gauges to measure pressure in the system are installed as required by the system engineer. A Cla-Val X101 Valve Position Indicator may be installed in the center cover port to provide visual indication of the valve stem during start-up.

CAUTION: During start-up and test procedures a large volume of water may be discharged downstream. Check that the downstream venting is adequate to prevent damage to personnel and equipment.

2. If the Pilot System shutoff valves (B) are installed, open valves. (see schematic).

3. Very slowly open the upstream block valve.

4. While the tank is filling, the float rod and link assembly (CF1-C1 item 19) can be moved slowly to the up position to manually close the main valve. This operation tests the closure of the Float Valve and also will purge air



from the control lines and cover chamber. Carefully loosen tube fittings at highest points and bleed air from system. Carefully loosen the plug at top of main valve cover. If an indicator is installed, carefully loosen the vent at top of indicator. If the valve is installed on its side loosen the top 4 cover bolts to bleed air trapped in the cover. Bleed air from cover and tighten plug. Tighten tube fittings.

Maintenance

1. Cla-Val Valves and Controls require no lubrication or packing and a minimum of maintenance. However, a periodic inspection schedule should be established to determine how the fluid handled is affecting the efficiency of the valve assembly. Minimum of once per year.
2. Repair and maintenance procedures of the Cla-Val Hytrol main Valve and the control components are included in a more detailed IOM manual. It can be downloaded from our web site (www.cla-val.com) or obtained by contacting a Cla-Val Regional Sales Office.
3. **When ordering parts always refer to the catalog number and stock number on the valve nameplate.**

SYMPTOM	PROBABLE CAUSE	REMEDY
Continuous flow from float pilot system discharge port	Damaged valve diaphragm	Replace diaphragm
	Loose main valve (1) stem nut	Tighten stem nut
	Damaged float pilot control (2)	Replace pilot valve assembly (See P-CF1-C1)
Main Valve fails to close	Too low pressure differential across valve (Need 5 psi d Min under flowing conditions)	Restrict valve opening with Cla-Val X102A flow limiting assembly (Contact Cla-Val)
	Isolation valve in control tubing closed or clogged X46 strainer	Open isolation valve. clean strainer
	Float and float rod fails to move with liquid level change (stays in down position)	Free float mechanism
Main Valve fails to open	Float and float rod fails to move with liquid level change (stays in up position)	Free float mechanism
	Inlet gate or block valve closed	Open valve
Main Valve Vibrates when closing	Air in cover	Bleed all air with float in the up position

124-01/624-01 SCHEMATIC

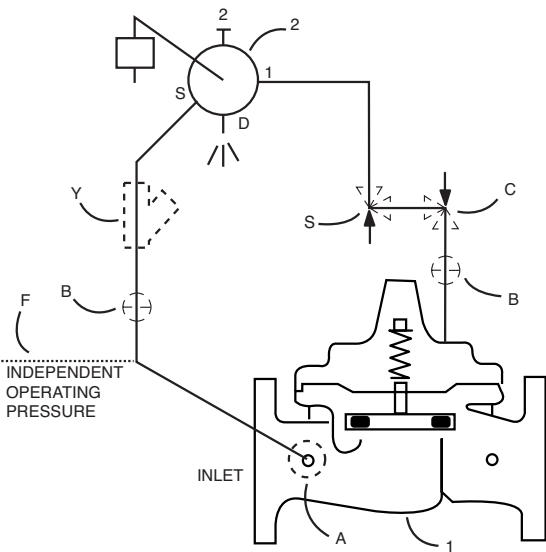

X140-1 Security Cap Option



BASIC COMPONENTS

- 1 100-01 Hytrol (Main Valve)
- 100-20 600 Series Hytrol (Main Valve)
- 2 CF1-C1 Float Control

OPTIONAL FEATURES

- A X46A Flow Clean Strainer
- B CK2 (Isolation Valves)
- C Closing Speed Control
- F Independent Operating Pressure
- S Opening Speed Control
- Y X43 "Y" Strainer

HYTROL MAIN VALVE

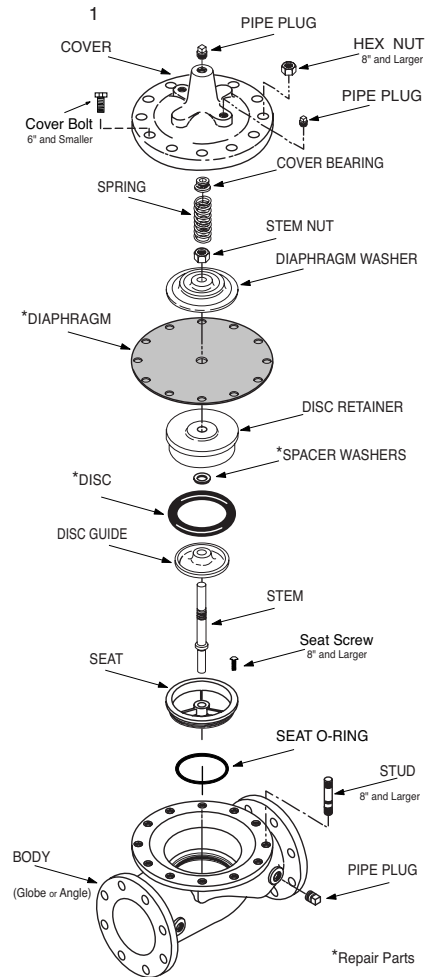

CF1-C1

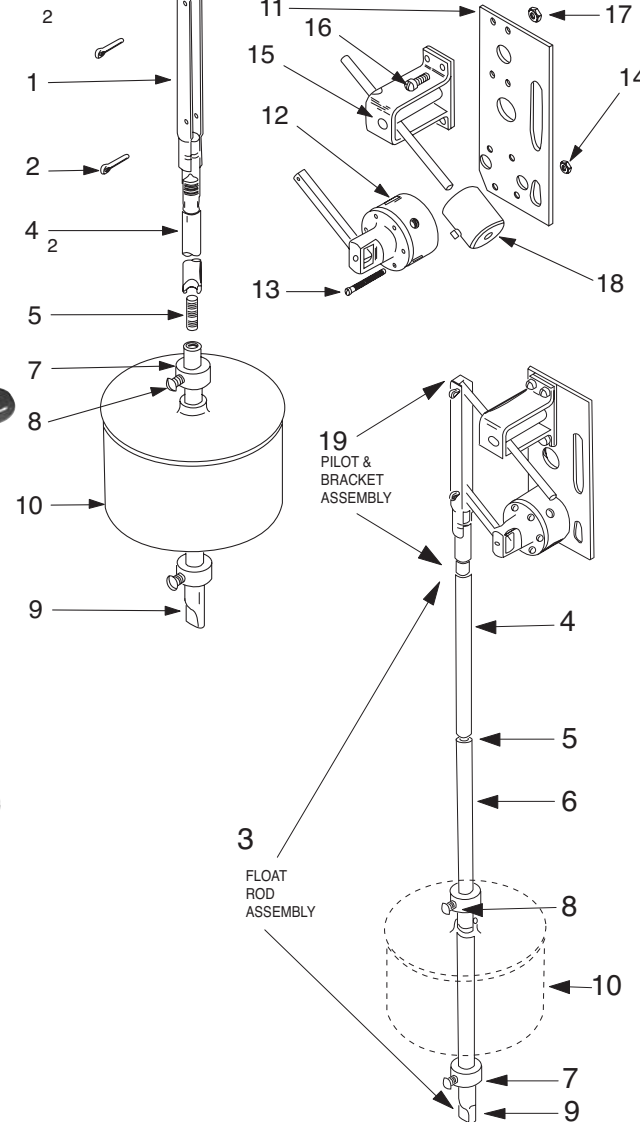

X46A
A



CK2
B



CV
C



X43
Y



ITEM	DESCRIPTION
1	Link Assembly
2	Cotter Pins (2 req'd)
3	Float Rod Assembly (2 ft.)
FLOAT ROD ASSY. BREAKDOWN ITEMS 4 - 9	
4	Upper Float Rod (1 ft.)
	Upper Float Rod (2 ft.)
5	Stud (Req. for connecting upper and lower rods and one for each extension rod)
6	Extension Float Rod (1 ft.)
	Extension Float Rod (2 ft.)
7	Stop Collar (2 req'd)
8	Set Screw (1 ea. stop collar)
9	Lower Float Rod (1 ft.)
	Lower Float Rod (2 ft.)
10	Float Ball
11	Base and Mounting Plate
12	Pilot Valve Assembly CF1-C1
13	Machine Screw 6/32 x 1 1/2" (6 req'd.)
14	Hex Nut 6/32 (6 req)
15	Counter Balance Bracket Assy.
16	Machine Screw 10/32 x 9/16" (4 req'd.)
17	Hex Nut 10/32 (4 req'd.)
18	Counterweight (varies with rod length, includes set screws)
19	Pilot & Bracket Assembly CF1-C1
COUNTERWEIGHT NOT INCLUDED	